

# AQUILA AUDAX



automotive service equipment



# AQUILA AUDAX

## Smontagomme automatico con tecnologia “SENZA LEVA” Velocità e sicurezza su ogni tipo di ruota

L'**AQUILA AUDAX** è uno smontagomme automatico “**SENZA LEVA**” per ruote fino a **30"**, ideale per il montaggio e smontaggio di cerchi e pneumatici particolarmente delicati o difficili, dai low profile a tutti i run flat. Grazie alla tecnologia “SENZA LEVA” tutte le operazioni su cerchio e pneumatico sono svolte con semplicità eliminando il rischio di danneggiamenti e abbattendo i tempi di lavoro.

Caratteristiche peculiari di questo prodotto sono l'**ingombro ridotto** ideale anche per operare in spazi ristretti, l'attenzione all'**ergonomia** di altezze di lavoro e comandi, e il **gruppo stallonatore monobraccio** rotativo di 180° che garantisce una stallonatura rapida e precisa su entrambi i fianchi del pneumatico. L'autocentrante è a **platorello** e la velocità di rotazione è modulabile automaticamente.

Ogni componente è ottimizzato per prestazioni e durata nel tempo per garantire un investimento duraturo.

**AQUILA AUDAX** is an automatic “**LEVERLESS**” tyre changer for rims up to **30"**, which is ideal for mounting and demounting jobs involving particularly delicate or difficult wheels and tyres - from low profile tyres to all types of run flat tyre. “**LEVERLESS**” technology means that all operations on the rim and tyre are performed with extreme simplicity, eliminating the risk of damage and cutting job times significantly. The most significant characteristics of this machine are its **compactness**, which makes it ideal for use where space is limited, an **ergonomic design**, with optimum working heights and control positions, and the **180° rotating single arm bead breaker**, for rapid and precise bead breaking on both sides of the tyre. The machine also features an **axially clamping wheel support plate**, with automatically adjustable rotation speed.

Each component is optimised for superlative performance and durability to ensure maximum returns on your investment for years to come.

**1-2-3.** Gruppo stallonatore monobraccio **rotativo di 180°** (Patent Pending) per una stallonatura precisa, ripetitiva e rapida sui 2 fianchi.

**180° rotating** single arm bead breaker (Patent Pending), for precise, reliable and rapid bead breaking on both sides of the tyre.

**4.** Pannello comandi.  
Control panel.

**5. Procedura rapida** con disco stallonatore (particolarmente indicata con fianchi duri) per lo smontaggio del tallone inferiore

**Rapid bottom** bead demounting procedure with bead breaker disc (particularly useful with stiff sidewalls)



Automatic tyre changer with “**Leverless**” technology  
**Faster, safer work with all wheel types**

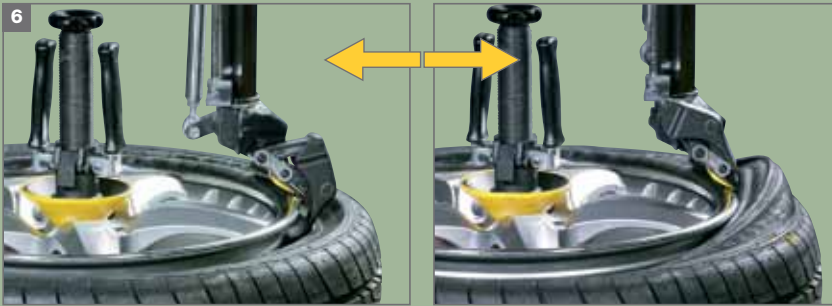

**6.** Smontaggio del tallone superiore  
*Demounting upper bead*



**7. Gruppo Stallonatore** - Movimento ad azionamento pneumatico di apertura laterale del braccio per consentire il posizionamento sul fianco inferiore  
**Bead Breaker** - *Pneumatic lateral arm movement, allowing placement of bead breaker on bottom side of tyre*



**8.** Sistema di penetrazione controllata per semplificare la stallonatura delle ruote più impegnative (Patent Pending)  
*Controlled penetration system to simplify bead breaking jobs with more difficult wheels (Patent Pending)*

**Dimensioni** Dimensions

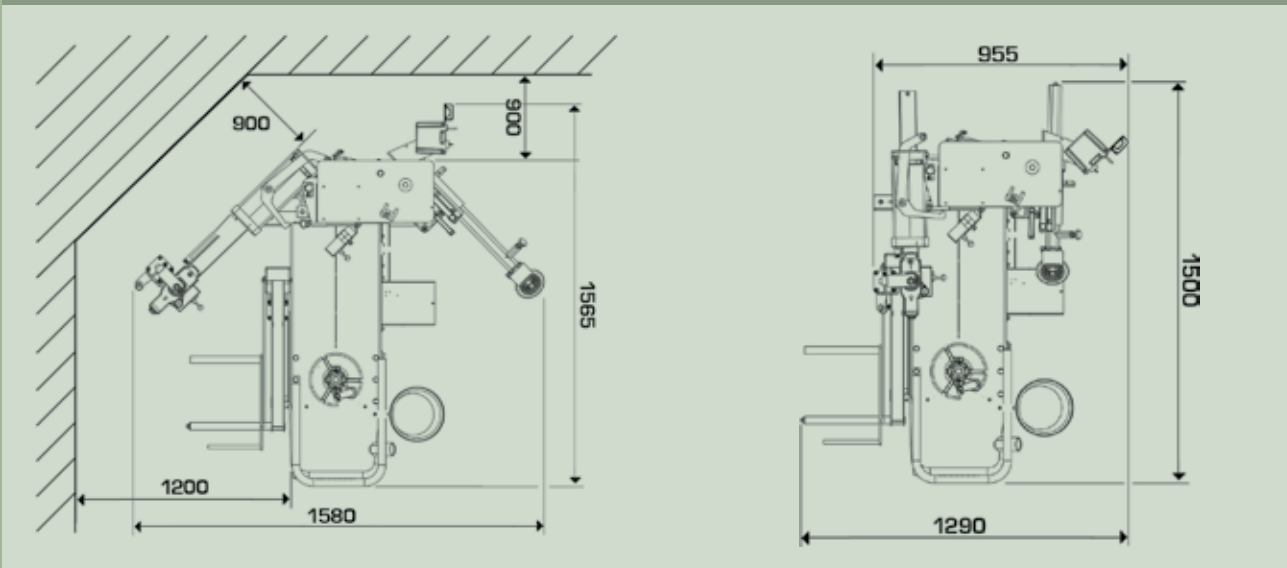

## AQUILA AUDAX

Accessori optional Optional accessories

E' disponibile una vasta gamma di accessori optional per tutte le necessità del mercato.

An extensive range of optional accessories are available to meet all the needs of industry professionals.



Premitallone pneumatico/Pneumatic bead pressing tool



Kit Sollevatore ruota / Wheel lift



Flangia universale cerchi ciechi/Flange for universal closed centre rim kit

Kit cerchi furgone/van rim kit

Flangia per ruote canale rovescio/Flange for reverse rim wheels



**MONDOLFO FERRO S.p.A. - a NEXION GROUP COMPANY**  
Viale Dell'Industria, 20 - 61037 MONDOLFO (PU) ITALY  
Tel. 0721.93671 - Telefax 0721.930238  
info@mondolfoferro.it - www.mondolfoferro.it

### Dati Tecnici Technical specifications

#### ► RANGE DIMENSIONI RUOTA WHEEL SIZE RANGE

diametro cerchio  
rim diameter **12" - 30"**

diametro max pneumatico  
max. tyre diameter **1200 mm (47")**

larghezza massima pneumatico  
maximum tyre width **15" (dal piano appoggio ruota)**  
15" (from the wheel supporting base)

pneumatici trattabili  
tyre types processed **convenzionali, low profile e Run Flat**  
conventional, low profile and Run Flat

#### ► AUTOCENTRANTE TURNTABLE

bloccaggio  
clamping **meccanico-manuale**  
mechanical-manual

motorizzazione  
drive system **motoinverter 2 velocità**  
2-speed inverter motor

coppia di rotazione  
rotation torque **1100 Nm**

velocità di rotazione  
rotational speed **7-18 rpm**

#### ► STALLONATORE BEAD BREAKER

campo massimo di stallonatura  
maximum bead breaking range **670 mm**

corsa stallonatore  
bead breaker stroke **540 mm**

forza stallonatore  
bead breaker force **7600 N**

#### ► CARICO/SCARICO RUOTA WHEEL LOADING/UNLOADING

azionamento  
operation **pneumatico**  
pneumatic

peso max ruota  
max wheel weight **85 Kg**

#### ► ALIMENTAZIONE POWER

elettrica 1Ph  
electric 1Ph **230V-0.98 kW 50Hz/60 Hz**

elettrica 1Ph (alternativa)  
electric 1Ph (alternative) **110V-0.98 kW 50Hz/60 Hz**

pneumatica di esercizio  
pneumatic operating pressure **8 bar (min)**

peso con sollevatore  
weight with lifter **310 kg**

Watch the demo video >



[www.facebook.com/MONDOLFOFERROspa](http://www.facebook.com/MONDOLFOFERROspa)



<http://www.youtube.com/user/MondolfoFerro>



L'azienda si riserva di modificare le caratteristiche del prodotto in qualsiasi momento.  
The company reserves the right to modify the technical specifications of its products at any time.

by Marketing - Cod. DPMF000239B - I-UK - 08/2013.